

MAIN APPLICATIONS

- Extrusion, injection, blow moulding, thermoforming of plastics
- Vulcanization of rubber
- Synthetic fibre production and polymerisation
- Packing and packaging
- Dryers for ceramics and building elements
- Industrial electric ovens
- Food processing plants
- Chemical and pharmaceutical industry



MAIN FEATURES

- Ultra-compact dimensions from 15A to 120A
- DIN rail and panel mounting
- Switching at zero voltage changeover
- Input command from DC/AC logic signal with push-in connectors; signalling leds
- Cage clamps for power cables
- Load voltage 480V, 600V AC
- Thermal alarm option with led and alarm output
- Interrupted load option with led and alarm output
- Internal overvoltage protection

PROFILE

Correct management of electrical heating elements for industrial heating applications

requires robust, safe, interference-free, fast and diagnostically capable static contactors.

The range of static contactors with GRS-H heatsink meets all these requirements, with current ratings from 15 to 120 Amperes and voltages up to 600 V AC, with extremely compact size in every single current level. The thermal design of all models guarantees the continuous supply of the rated current at an ambient temperature of 40°C through high efficiency heat sinks, assisted by fans for the 90A and 120A models.

The derating curves show how higher current values can also be achieved, at lower temperatures, and illustrates the possibility of mounting various devices packed together on the DIN rail.

GRS COMMAND SIGNAL CONNECTION

The GRS-H series can be controlled by DC and AC logical signals managed through push-in connectors for a faster and easier connection, even without tools.

The ON / OFF status of the static device is always displayed by a green

LED on the front panel, for an immediate view of its operation.

POWER CONNECTIONS

Both the line voltage terminal available on the upper part of the device and the load terminal on the lower part are of the “cage” type, which offers the best and safest seal even for cables of different cross-sections, whether mounted with a cable lug or simply stripped.

DIAGNOSTICS AND ALARMS

It is increasingly vital for operators and maintainers to recognize possible anomalies in the system immediately and solve them quickly in order to ensure the efficiency and profitability of machinery and plants. The GRS-H series offers a series of diagnostic information associated with a physical alarm output with voltage-free or PNP-type isolated contact.

The thermal alarm is triggered if heat dissipation exceeds a critical threshold, signalling it with a yellow led on the front panel, interrupting the power supply and triggering the alarm output (NO or NC). This function is available for all sizes as an option.

The absence of current on the load (for models with DC control) is indicated by a red led on the front panel and by the activation of the alarm

output, as well as by the absence of line voltage.

Alarm output status is memorized: in the presence of a 24 V DC auxiliary power supply, the alarm will be memorized even in the event of an OFF command.

The alarm is reset when normal operating conditions are restored, or when the 24 V DC auxiliary power supply is switched off and on again.

TECHNICAL DATA

MAIN FEATURES

Category of use: AC51
Rated working voltage
- 480Vac (max. range 24...530Vac)
- 600Vac (max range 24 ... 660Vac)
Rated frequency: 50/60Hz
Non-repetitive voltage:
• 11200Vp for model with rated voltage 480Vac
• 1400Vp for model with rated voltage 600Vac
Switching voltage for zero: < 20V
Activation time: = 1/2 cycle
Deactivation time: = 1/2 cycle
Potential drop at rated current:
= < 1,2Vrms
Power factor = 1

CONTROL INPUT

- DC INPUT (Type "D"):
Max. input: < 9mA @32V
Max. reverse voltage: 36Vdc
Control voltage: 6...32Vdc
Activation voltage: > 5,1Vdc
Deactivation voltage:< 3Vdc

- AC INPUT (Type "A"):
Control voltage: 20...260 Vac/Vdc
INSTALL FUSE (3A MAX) ON THE CONTROL INPUT CIRCUIT
Activation voltage: > 15Vac/Vdc
Deactivation voltage: < 6Vac/Vdc
Current draw: <= 8 mAac/dc @ 260 Vac/Vdc

Alarm Output Option
(Type "D" Input Version)
A load or line failure or an overtemperature alarm commands:

- Options 1/2/5: one voltage-free contact (solid state N.C or N.O.), max. properties:
- N.O. version 30V-150mA conduction resistance: $\leq 1\Omega$
- N.C. version 30V-50mA conduction resistance: $\leq 15\Omega$
- Option 3: two normally inactive (parallelable) PNP digital outputs, one for load failure and the other for overtemperature (properties: $I_{max} = 150mA$ $V_{out} = +V$ DC power supply -1V).

Maximum interrupted load alarm trip delay < 400ms
Maximum cable length between GRS-H and load for correct load fault diagnostics < 25m

Alarm Output Option
(Type "A" Input Version)
The over-temperature alarm commands a voltage-free contact (solid state N.C.), max. properties:
30V-50mA conduction resistance: $\leq 15\Omega$

OUTPUTS

GRS-H 15

Rated current: 15 A@40°C in continuous service
Non-repetitive overcurrent t=20 ms: 620A
I2t for blowout: $\leq 1800A^2s$
dV/dt critical with output deactivated: 1000V/ μs

GRS-H 25

Rated current: 25 A@40°C in continuous service
Non-repetitive overcurrent t=20 ms: 620A
I2t for blowout: $\leq 1800A^2s$
dV/dt critical with output deactivated: 1000V/ μs

GRS-H 30

Rated current: 30 A@40°C in continuous service
Non-repetitive overcurrent t=20 ms: 620A
I2t for blowout: $\leq 1800A^2s$
dV/dt critical with output deactivated: 1000V/ μs

GRS-H 40

Rated current: 40 A@40°C in continuous service
Non-repetitive overcurrent t=20 ms: 620A
I2t for blowout: $\leq 1800A^2s$
dV/dt critical with output deactivated: 1000 V/ μs

GRS-H 50

Rated current: 50 A@ 40°C in continuous service
Non-repetitive overcurrent t=20 ms: 1600A
I2t for blowout: $\leq 12800A^2s$
dV/dt critical with output deactivated: 1000V/ μs

GRS-H 60

Rated current: 60 A@ 40°C in continuous service
Non-repetitive overcurrent t=20 ms: 1600A
I2t for blowout: $\leq 12800A^2s$
dV/dt critical with output deactivated: 1000V/ μs

GRS-H 75

Rated current: 75 A@ 40°C in continuous service
Non-repetitive overcurrent t=20 ms: 1600A
I2t for blowout: $\leq 12800A^2s$
dV/dt critical with output deactivated: 1000V/ μs

GRS-H 90

Rated current: 90A@ 40°C in continuous service (complete with specified fan)
Non-repetitive overcurrent t=20 ms: 1500A

I2t for blowout: $\leq 11250A^2s$
dV/dt critical with output deactivated: 1000V/ μs

GRS-H 120

Rated current: 120A@ 40°C in continuous service (complete with specified fan)
Non-repetitive overcurrent t=20 ms: 1500A
I2t for blowout: $\leq 11250A^2s$
dV/dt critical with output deactivated: 1000V/ μs

THERMAL PROTECTION

(Optional, always present in GRS-H with current size $\geq 50A$):
The temperature of the SCR module is constantly monitored inside the device.
When the maximum temperature threshold of the internal SCR is exceeded, current conduction to the load is interrupted and the yellow thermal protection LED comes on to signal the condition.

ISOLATION

Rated isolation voltage input/output: 4000VACrms 1min

AMBIENT CONDITIONS

- **Working temperature:** from 0 to 80°C (according with heat sink curves)
- **Max. relative humidity:** 90% non-condensing at 40°C
- **Max. installation altitude:** 6600ft above sea level
- **Pollution level :** 2
- **Storage temperature:** -20..+85°C

INSTALLATION NOTES

Use the extra-rapid fuse shown in the catalogue according to the connection example supplied.

Applications with static units must also include a safety circuit breaker for disconnecting the power line from the load.

To obtain high reliability of the device, it is essential to install it correctly inside the panel in order to obtain adequate heat exchange between the heat sink and the surrounding air under conditions of natural convection.

Mount the device vertically (maximum 10° inclination from the vertical axis)

- Vertical distance between a device and the panel wall >100mm
- Horizontal distance between a device and the panel wall at least 20mm
- Vertical distance between one

device and another at least 100mm.

- Horizontal distance between one device and another at least 20mm (in the event of installation at shorter distances, see derating curves).

Make sure that the cable ducts do not reduce these distances; in this case, mount the units overhanging the panel, so that the air can flow vertically on the heat sink without hindrance.

LIMITS OF USE

- Ambient temperature limits, depending on derating curves.
- Need for air exchange with the outside or an air conditioner to transfer the dissipated power to the outside of the panel.
- Installation limits (distances between devices to ensure dissipation under natural convection conditions)
- Maximum voltage limits and derivative of the transients present on

the line, for which the static unit provides internal protection devices (depending on the models).

- Presence of leakage current < 3mA (max. value with nominal voltage and junction temperature of 125°C).

DIMENSIONS AND MOUNTING MEASUREMENTS

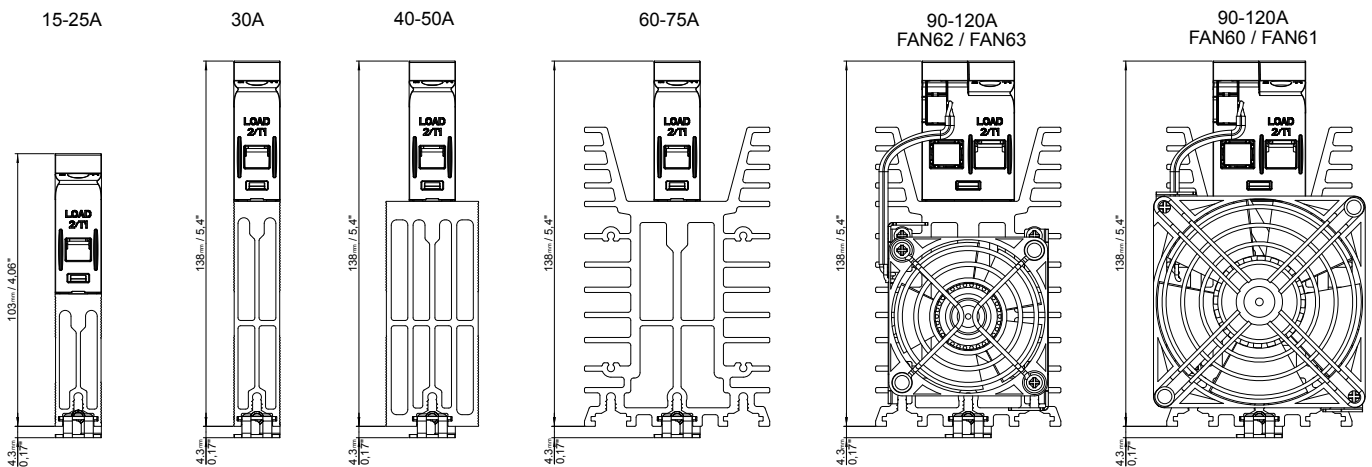
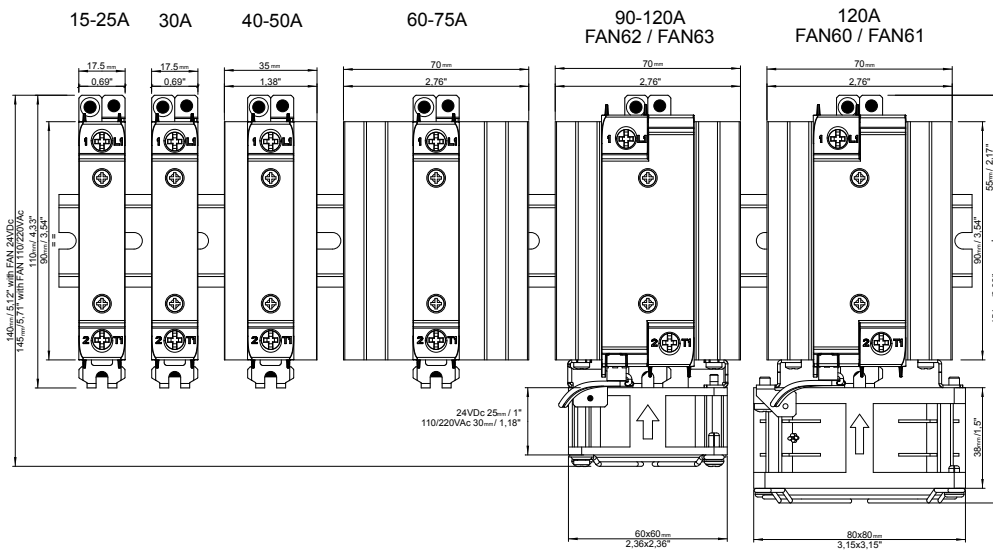

Model	15-25A	30A	40-50A	60-75A	90-120A
Weight [g]	194	237	388	688	796

Notes:

The dimensions are representative of all models of the series (command "D" type, "A" type and with options)

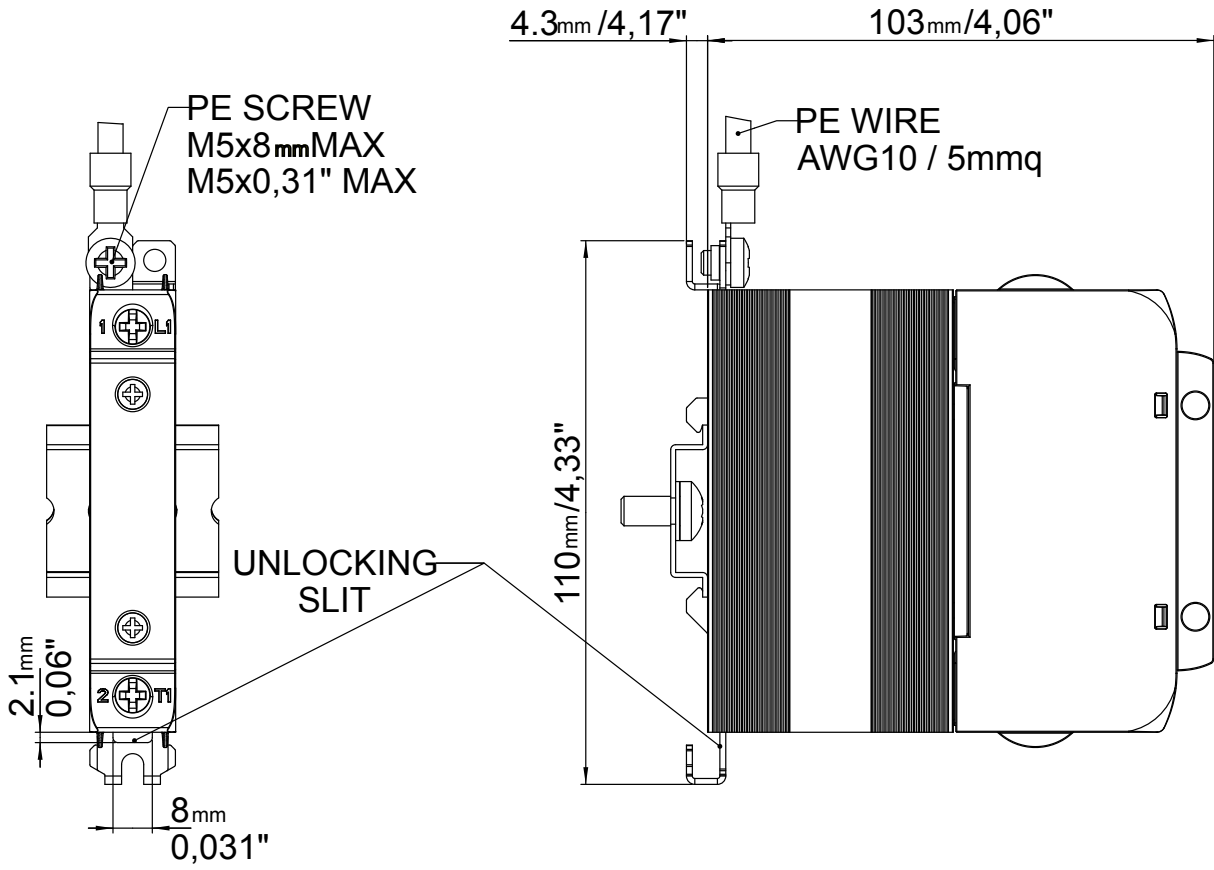

DIN rail coupling sequence

DIN rail release sequence

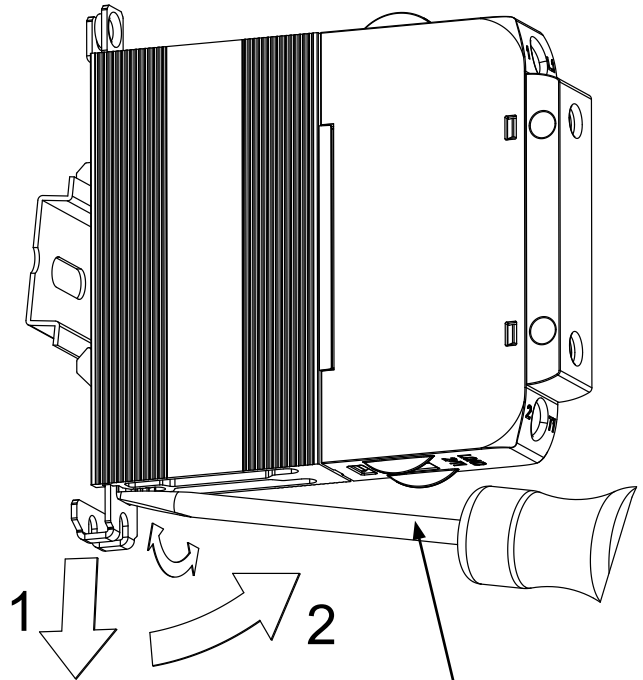
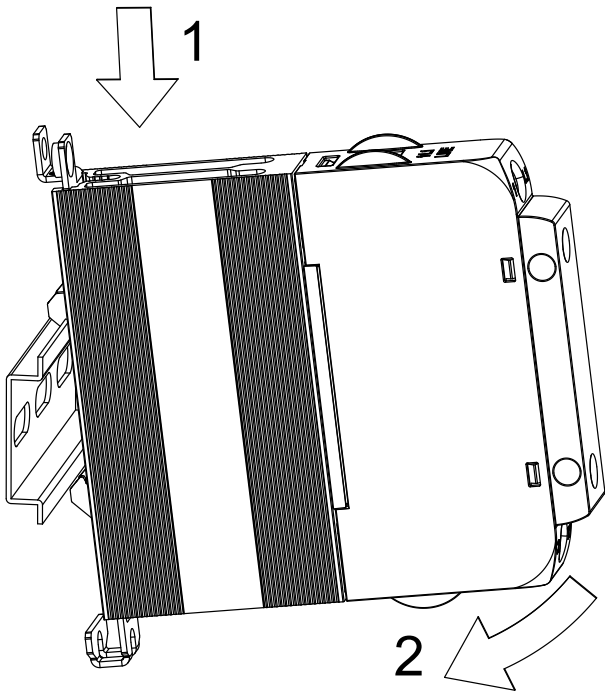

SCREW DRIVER (*)

(*) Use of a slotted screwdriver with a max. diameter of 6mm is recommended

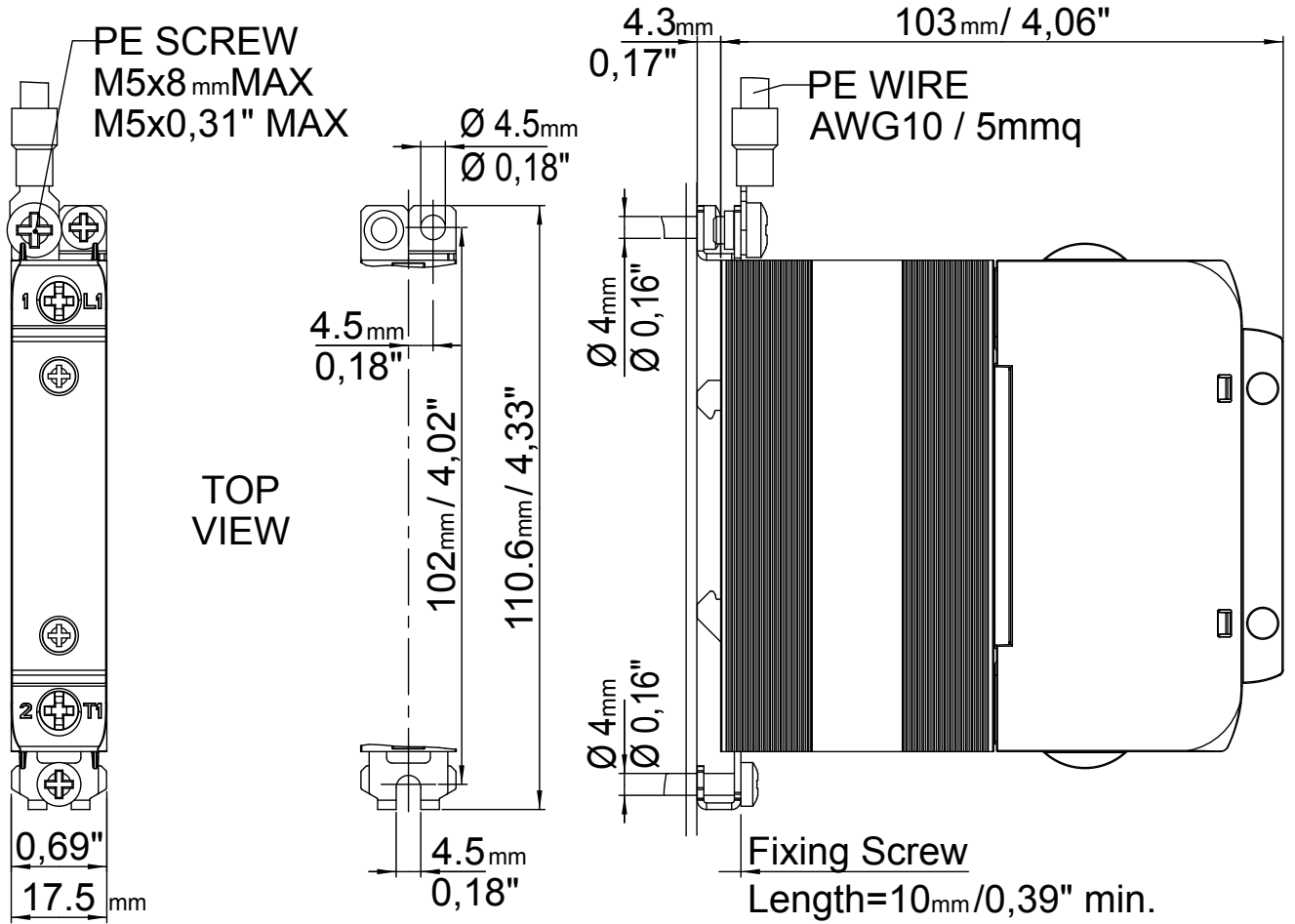

GRS-H...D-0

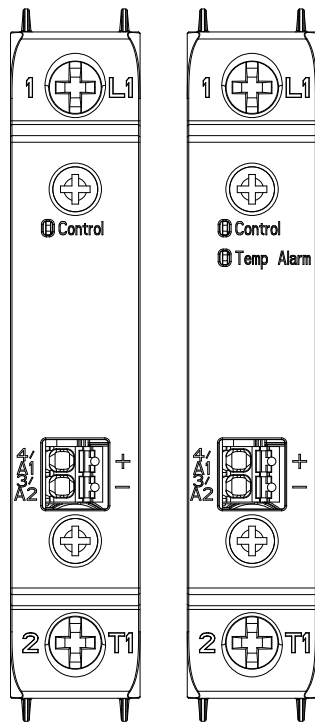

GRS-H...D-1

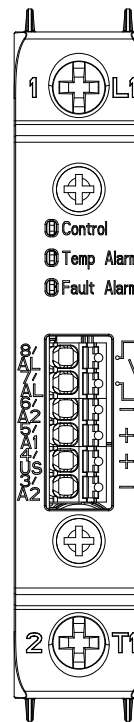

GRS-H...D-2

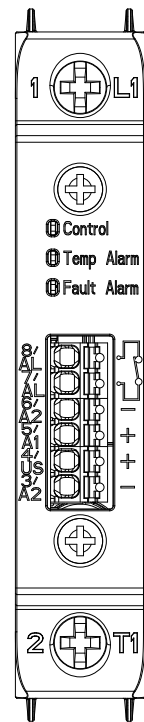

Description of terminal/connector versions with type "D" input

Power terminals (common to all versions) (Overvoltage Category III)

Rif.	Description	Notes
1/L1	Line Connection	
2/T1	Load Connection	

Signal connector version without options (GRS-H...D-0) (Overvoltage Category II o III)

3/A2-	GND Control input ON/OFF	Control input ground
4/A1+	+Vdc control input ON/OFF	Range from 6 to 32 Vdc, I _{max} <9 mA a 32V

Signal connector version with options "1" and "2" type (GRS-H...D-1/2) (Overvoltage Category II o III)

3/A2-	GND for power supply and control input ON/OFF	Ground for power supply and control input ON/OFF	
4/Us	+ Vdc power supply	Power supply GRS-H (Range from 6 to 32 V DC, I _{max} < 14 mA at 32V GRS-H-90..120A-..FAN63: Power supply GRS-H + Fan (Range from 20 to 27 V DC, I _{max} <150 mA at 24V with Fan active)	
5/A1+	+Vdc control input ON/OFF	Range: ON from 5 to 32Vdc, I _{max} <0,5 mA a 32V OFF < 1,8V	
6/A2-	GND Control input ON/OFF (common to terminal 3/A2-)	Additional connection to be used only as GND for the control signal	
		Version with option 1	Version with option 2
7/AL	Alarm output:	Solid state N.O. contact I _{max} =150mA V _{max} = 30 V DC/25V AC Z _{closed} < 1 Ω Z _{open} > 1 MΩ	Solid state N.C. contact I _{max} = 50mA V _{max} = 30 Vdc/25Vac Z _{closed} < 15 Ω Z _{open} > 1 MΩ
8/AL	- Interrupted load - Line voltage absent - Overtemperature		

Note:

The connections are also representative of 90-120A models

For terminals and conductors to be used, see the table: "CLAMP AND CONDUCTOR CHARACTERISTICS TABLE" on page 14

GRS-H...D-3

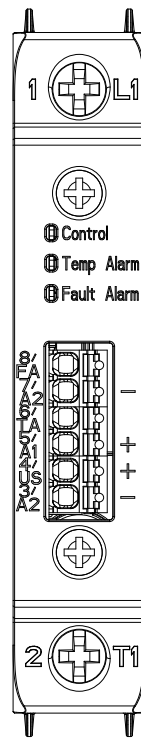

GRS-H...D-5

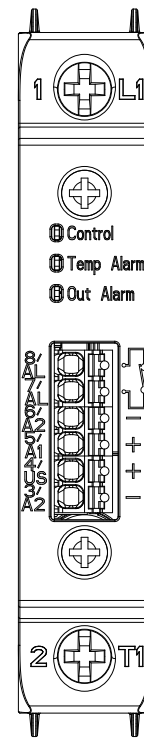

Description of terminal/connector versions with type "D" input

Signal connector version with option type "3" (GRS-H...D-3) (Overvoltage Category II o III)

Rif.	Description	Notes
3/A2-	GND for power supply and control input ON/OFF	Ground for power supply and control input ON/OFF
4/US	+ Vdc power supply	Power supply GRS-H (Range from 10 to 32 Vdc, I _{max} < 14 mA a 32V) GRS-H-90..120A-..FAN63: Power supply GRS-H + Fan (Range from 20 to 27 V DC, I _{max} <150 mA at 24V with Fan active)
5/A1+	+Vdc control input ON/OFF	Range: ON da 5 a 32Vdc, I _{max} <0,5 mA a 32V OFF < 1,8V
6/TA	Overtemperature alarm output	PNP output normally not active (1) I _{max} =150mA Vout: + V DC power supply -1V
7/FA	Alarm output: interrupted load or line voltage absent	PNP output normally not active (1) I _{max} =150mA Vout: + V DC power supply -1V
8/A2-	GND Control input ON/OFF (common to terminal 3/A2-)	Additional connection to be used only as GND for the control signal

Alarm output connector version with type "5" option (GRS-H...A-5) (Overvoltage Category II o III)

3/A2-	GND for power supply and control input ON/OFF	Ground for power supply and control input ON/OFF
4/Us	+ Vdc power supply	Power supply GRS-H (Range from 6 to 32 V DC, I _{max} < 14 mA at 32V) GRS-H-90..120A-..FAN63: Power supply GRS-H + Fan (Range from 20 to 27 V DC, I _{max} <150 mA at 24V with Fan active)
5/A1+	+Vdc control input ON/OFF	Range: ON from 5 to 32Vdc, I _{max} <0,5 mA a 32V OFF < 1,8V
6/A2-	GND Control input ON/OFF (common to terminal 3/A2-)	Additional connection to be used only as GND for the control signal
7/AL	Overtemperature alarm output	Solid state N.C. contact I _{max} = 50mA V _{max} = 30 Vdc/25Vac Z _{closed} < 15 Ω Z _{open} > 1 MΩ
8/AL		

(1): The normally inactive PNP outputs can be connected to each other and obtain a single alarm output

Note:

The connections are also representative of 90-120A models

For terminals and conductors to be used, see the table: "CLAMP AND CONDUCTOR CHARACTERISTICS TABLE" on page 14

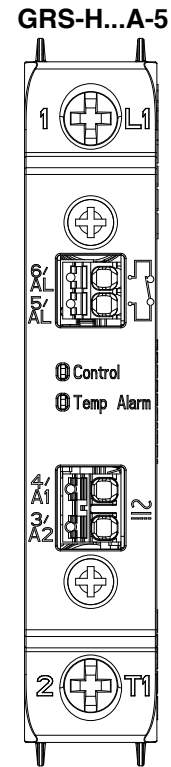
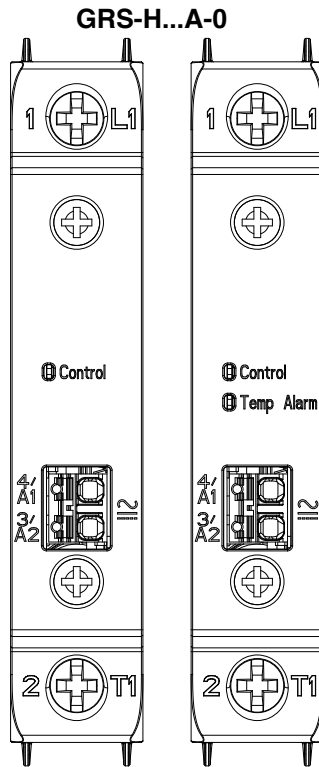

Description of terminal versions with type "A" input		
Power terminals (common to all versions) (Overvoltage Category III)		
Rif.	Description	Notes
1/L1	Line Connection	
2/T1	Load Connection	
"Control connector" (Overvoltage Category II)		
3/A2	Control input ON/OFF in AC	Vac/Vdc input (Range 20 to 260Vac/Vdc, I _{max} < 8 mA) Overvoltage Category II
4/A1		
Alarm output connector version with type "5" option (GRS-H...A-5) (Overvoltage Category II o III)		
5/AL	Overtemperature alarm output	Solid state N.C. contact I _{max} = 150 mA V _{max} = 30 Vdc/25Vac Z _{closed} < 1 Ω Z _{open} > 1 MΩ
6AL		
Note: The connections are also representative of 90-120A models For terminals and conductors to be used, see the table: "CLAMP AND CONDUCTOR CHARACTERISTICS TABLE" on page 14		

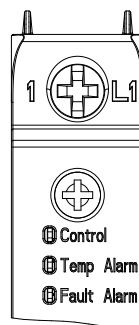

Note:
Control LED is always present,
Temp Alarm and Fault Alarm LEDs are optional

LED STATUS DESCRIPTION

STATUS	LED Control (Green)	LED Temp Alarm (Yellow)	LED Fault Alarm/Out Alarm (Alarm:Red)
SCR OFF, no alarm	OFF	OFF	OFF
SCR ON, no alarm	ON	OFF	OFF
SCR ON, Alarm output active	ON	OFF	ON
Control signal active, SCR forced off for overtemperature protection	OFF	ON	OFF
Control signal active, SCR forced off for overtemperature protection, Alarm output active	OFF	ON	ON
SCR off, Alarm output active for interrupted load (alarm is stored, Status only possible with GRS-H with Type D input and options 1/2/3)	OFF	OFF	ON

Logic voltage output command

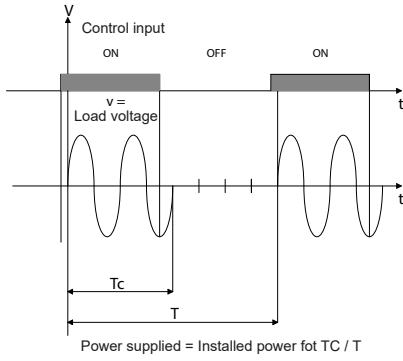

GRS-H thermal protection

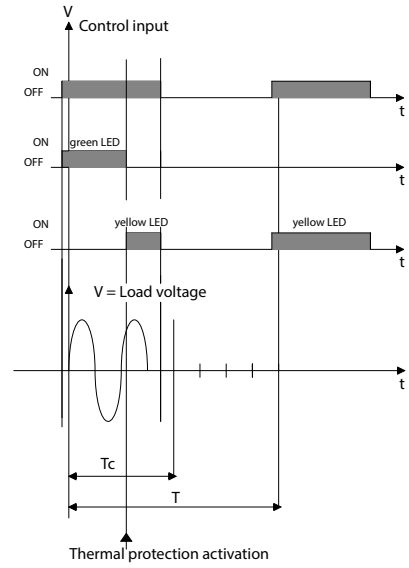

THERMAL ALARM

Models with thermal alarm

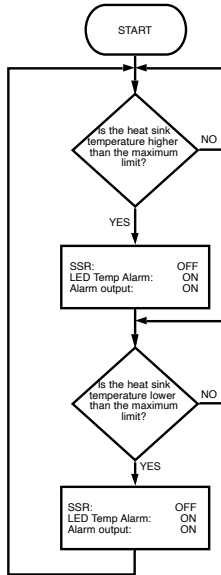

Models with thermal alarm and FAN63 option

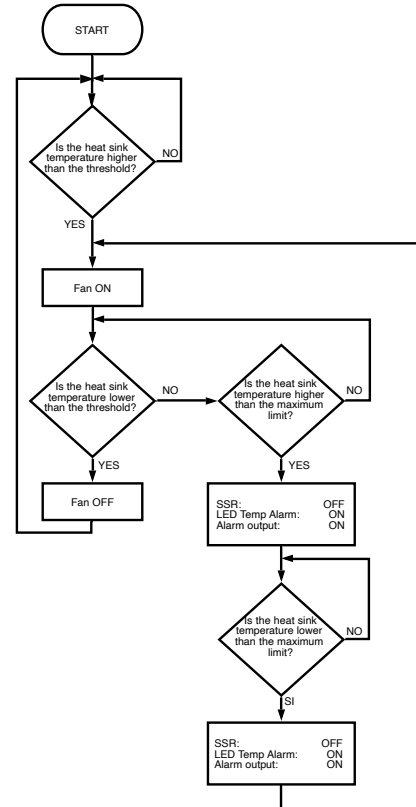

ALARM LOAD INTERRUPTED

GRS-H with V DC command (Control type "D" with options)

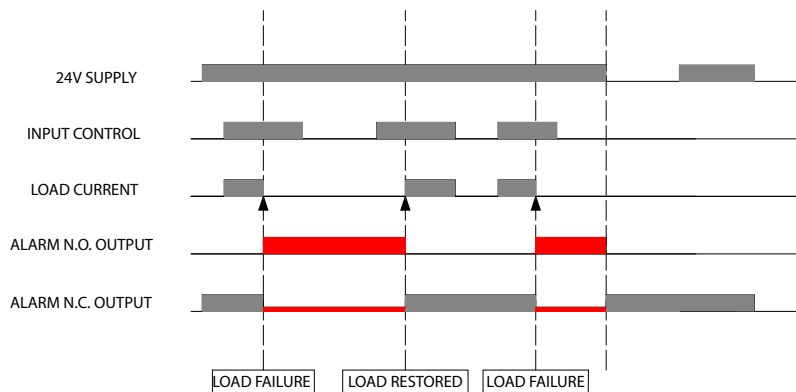

CONNECTION EXAMPLES

Single-phase connection - GRS-H with Vdc command input (Type "D" input)

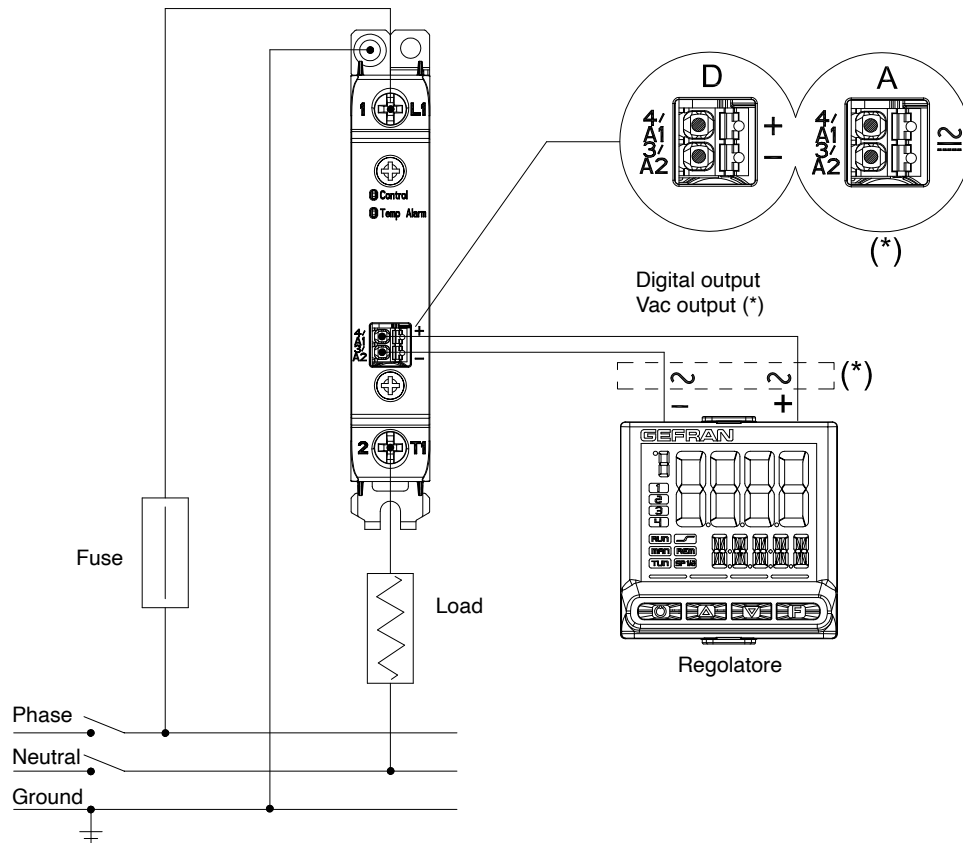

Three-phase Wye connection with neutral - GRS-H with V DC command input ("D" type input)

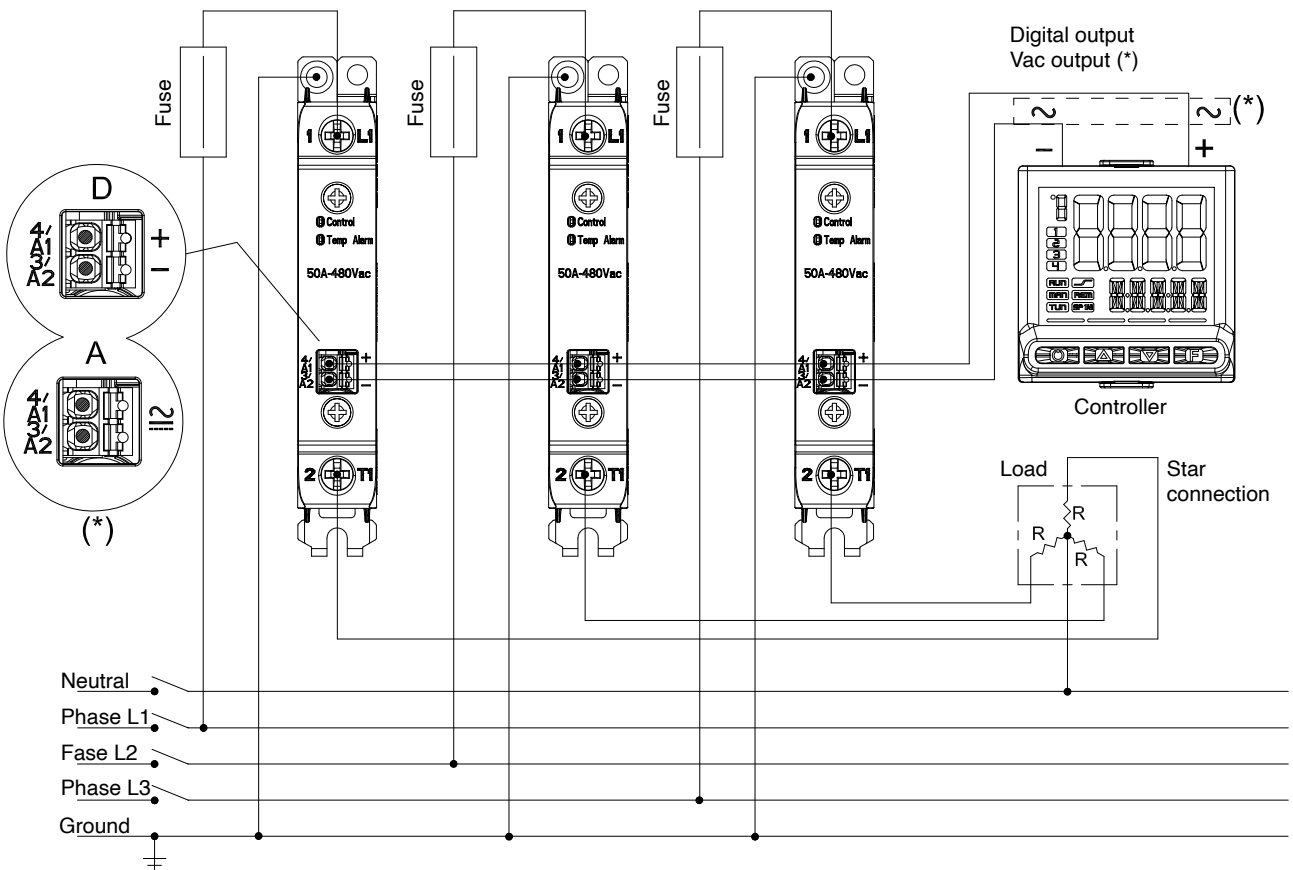

(*) Or relè output with Vac tension
(Use grs-h with comand input Vac type a)

CONNECTION EXAMPLES

Three-phase Triangle or Star connection without neutral on two phases - GRS-H with V DC command input ("D" type input)

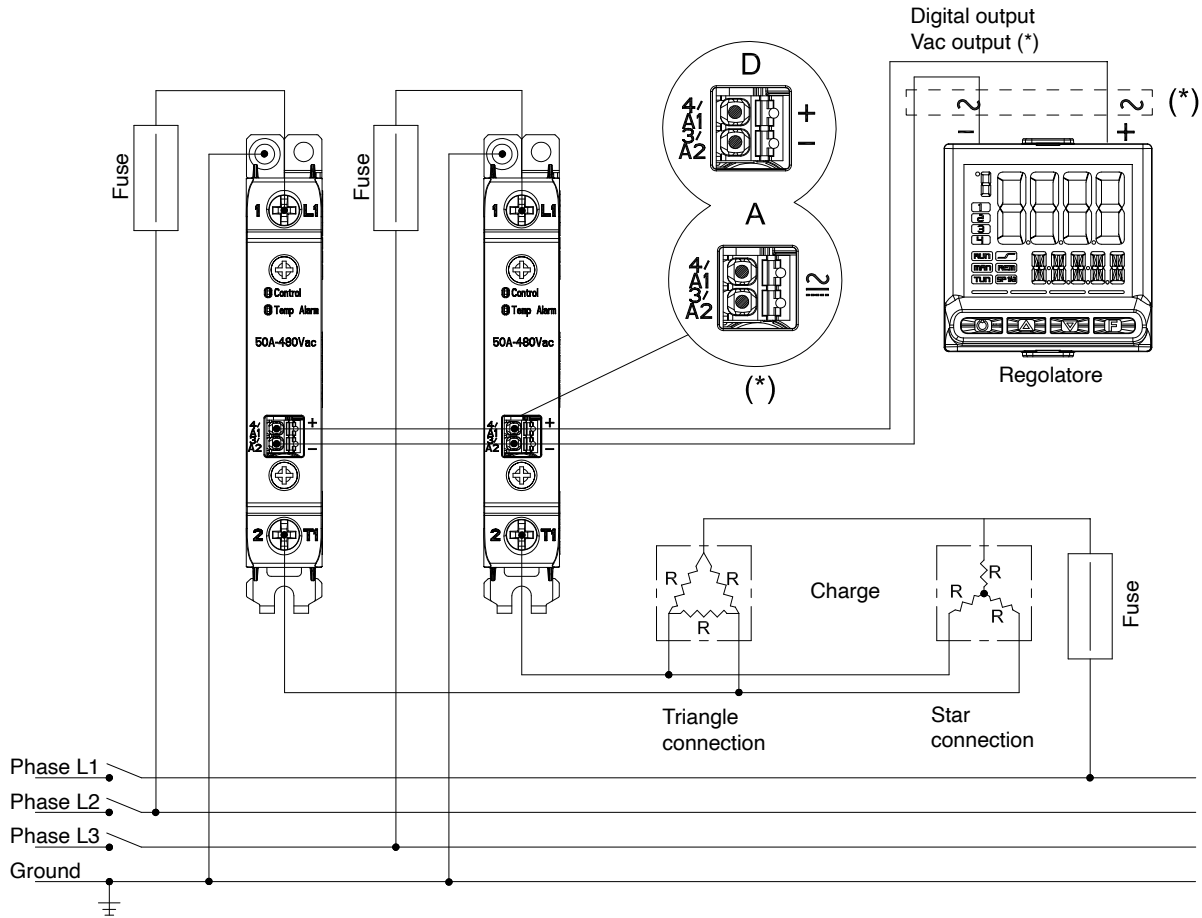

(*) Or relè output with Vac tension
(Use GRS-H with comand input vac type A)

Connection example for GRS-H with V DC command with isolated contact alarm output option (Options 1 and 2)

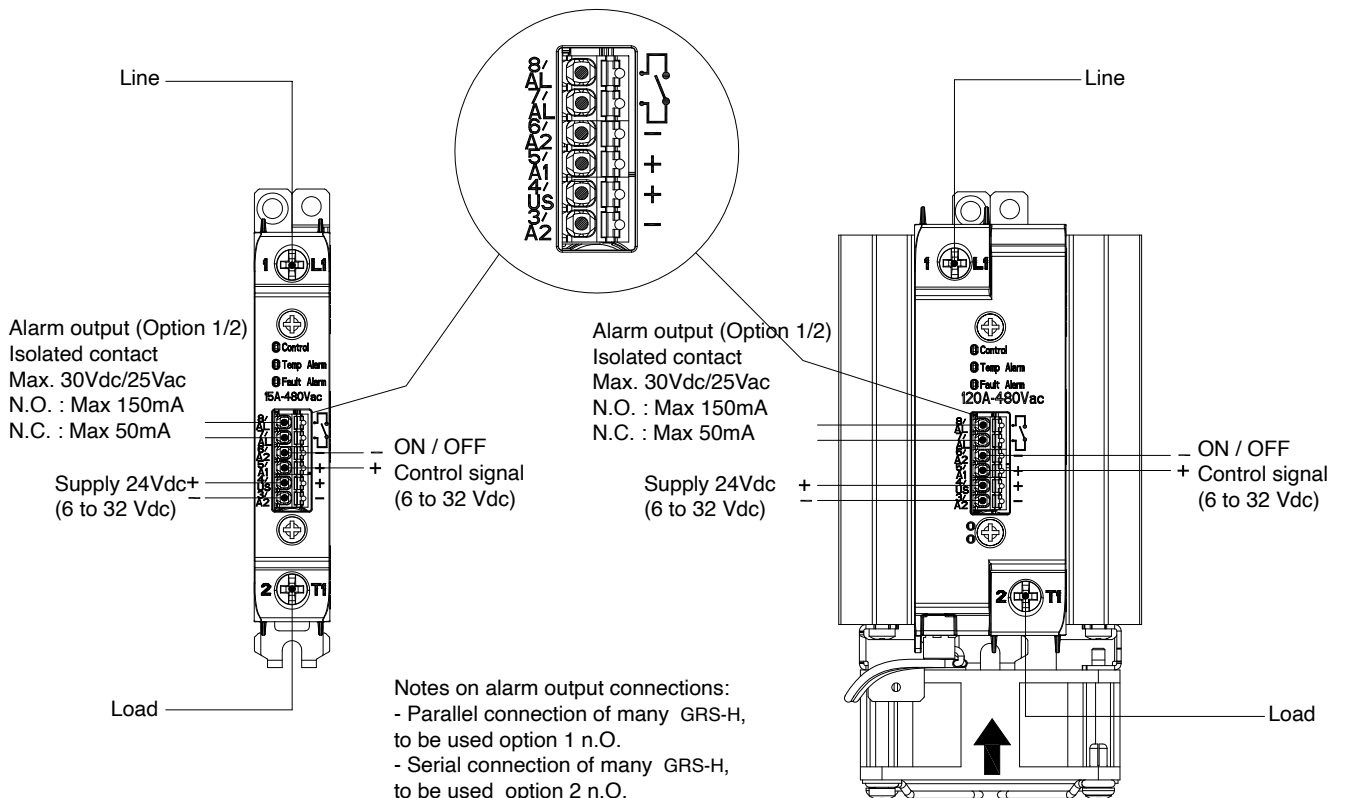

CONNECTION EXAMPLES

Connection example for GRS-H with V DC command with PNP alarm output option (Option 3)

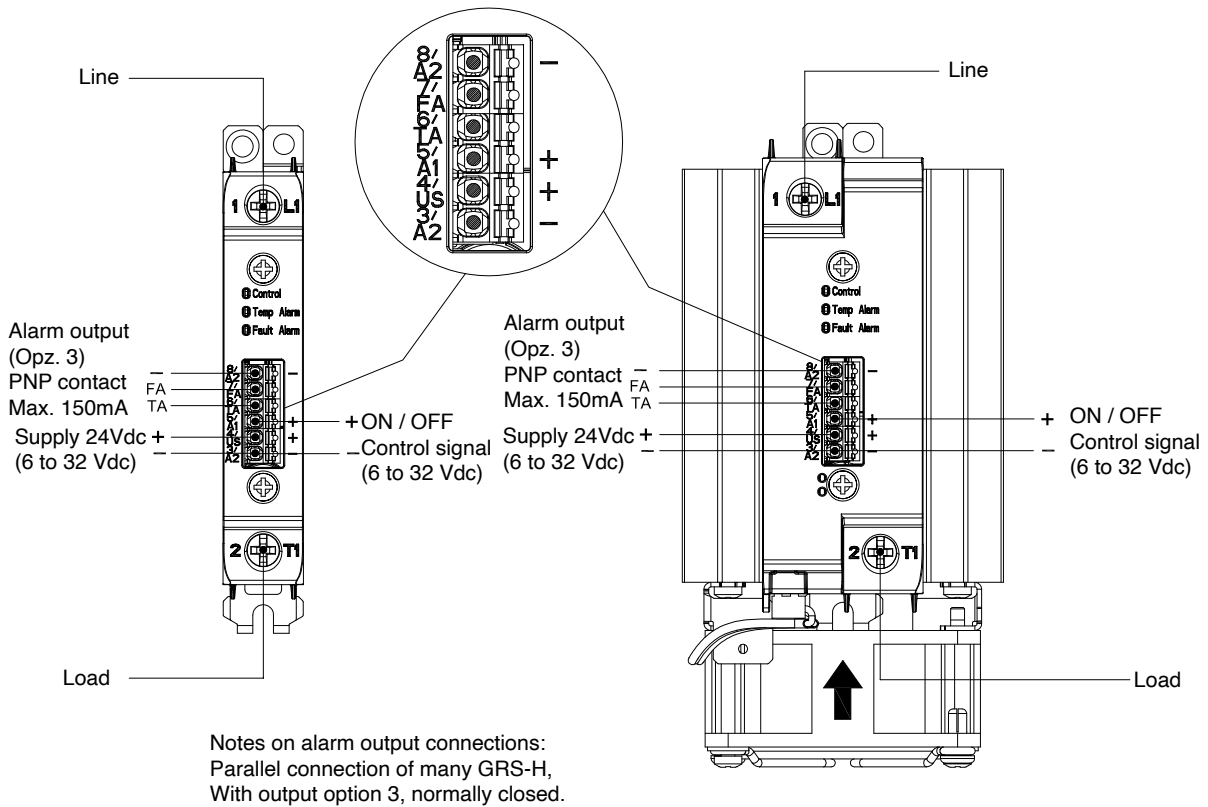

Connection example for GRS-H with V DC control with thermal alarm option (Option 5)

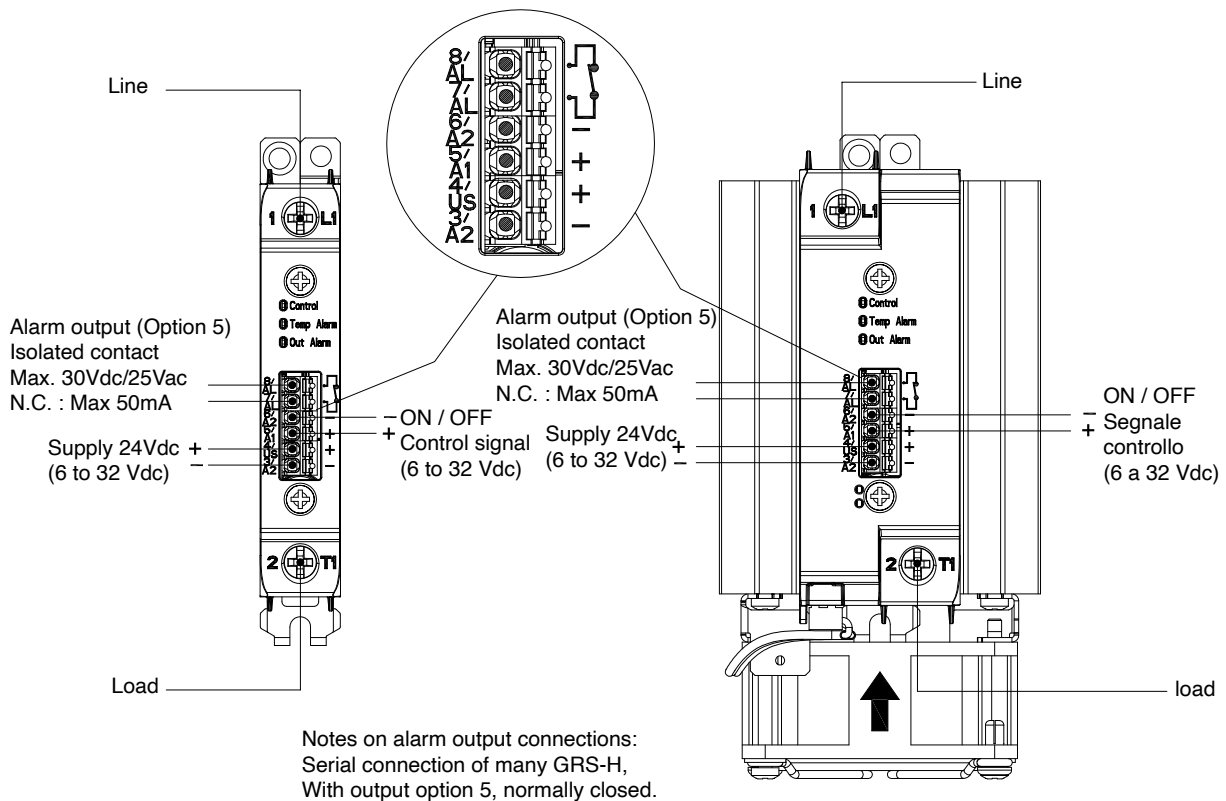

CONNECTION EXAMPLES

Connection example for GRS-H with V AC control with thermal alarm option (Option 5)

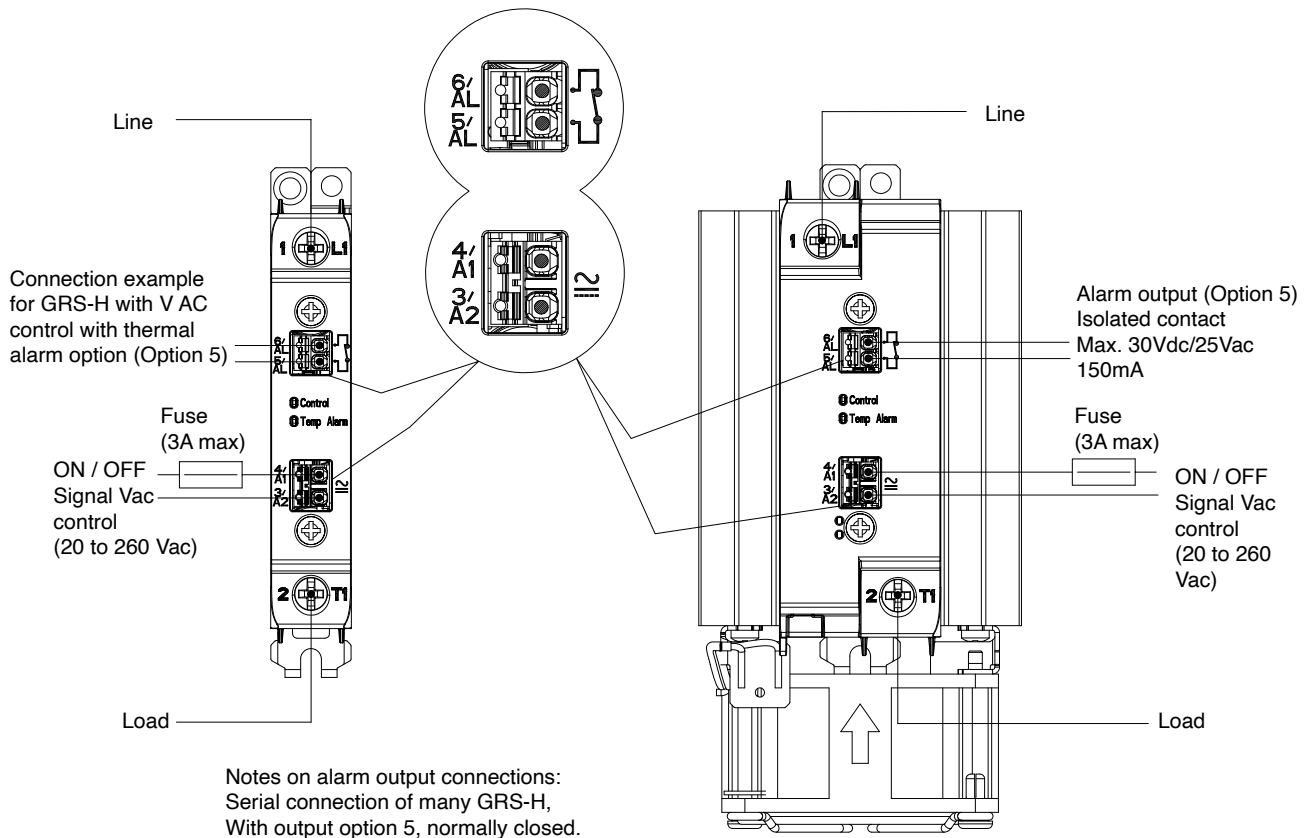

TABLE OF TERMINALS AND CONDUCTORS

CONTROL/SIGNAL TERMINALS			POWER TERMINALS			GROUND TERMINAL	
Size	Type of connection	Conductor section / Stripping length	Contact area (WxD) screw type	Type of connection	Conductor section / Tightening torque / Stripping length	Contact area (WxD) screw type	Tightening torque
15A	Rigid/flexible/cable lug conductor cross section	1 x 0.2-1.5 mm ² / 2 x 0.1-0.75 mm ² 1 x 24-16 AWG / 2 x 27-19 AWG	9,2 x 8 mm M5	Rigid/flexible/ferrule conductor cross section	1 x 2.5 mm ² / 2 x 1.5 mm ² 1 x 14 AWG / 2 x 17 AWG 2,5-3 Nm (22-26,6lb-in)	9 x 9 mm M5	1,5-2,5 Nm (13.3 lb-in – 22 lb-in)
	Stripping length	8 mm		Stripping length	11 mm		
25A	Rigid/flexible/cable lug conductor cross section	1 x 0.2-1.5 mm ² / 2 x 0.1-0.75 mm ² 1 x 24-16 AWG / 2 x 27-19 AWG	9,2 x 8 mm M5	Rigid/flexible/ferrule conductor cross section	1 x 10 AWG / 2 x 12 AWG 2,5-3 Nm (22-26,6lb-in)	9 x 9 mm M5	1,5-2,5 Nm (13.3 lb-in – 22 lb-in)
	Stripping length	8 mm		Stripping length	11 mm		
30A	Rigid/flexible/cable lug conductor cross section	1 x 0.2-1.5 mm ² / 2 x 0.1-0.75 mm ² 1 x 24-16 AWG / 2 x 27-19 AWG	9,2 x 8 mm M5	Rigid/flexible/ferrule conductor cross section	1 x 6 mm ² / 2 x 4 mm ² 1 x 10 AWG / 2 x 12 AWG 2,5-3 Nm (22-26,6lb-in)	9 x 9 mm M5	1,5-2,5 Nm (13.3 lb-in – 22 lb-in)
	Stripping length	8 mm		Stripping length	11 mm		
40A	Rigid/flexible/cable lug conductor cross section	1 x 0.2-1.5 mm ² / 2 x 0.1-0.75 mm ² 1 x 24-16 AWG / 2 x 27-19 AWG	9,2 x 8 mm M5	Rigid/flexible/ferrule conductor cross section	1 x 10 mm ² / 2 x 6 mm ² 1 x 8 AWG / 2 x 10 AWG 2,5-3 Nm (22-26,6lb-in)	9 x 9 mm M5	1,5-2,5 Nm (13.3 lb-in – 22 lb-in)
	Stripping length	8 mm		Stripping length	11 mm		
50A	Rigid/flexible/cable lug conductor cross section	1 x 0.2-1.5 mm ² / 2 x 0.1-0.75 mm ² 1 x 24-16 AWG / 2 x 27-19 AWG	9,2 x 8 mm M5	Rigid/flexible/ferrule conductor cross section	1 x 16 mm ² / 2 x 10 mm ² 1 x 6 AWG / 2 x 8 AWG 2,5-3 Nm (22-26,6lb-in)	9 x 9 mm M5	1,5-2,5 Nm (13.3 lb-in – 22 lb-in)
	Stripping length	8 mm		Stripping length	11 mm		
60A	Rigid/flexible/cable lug conductor cross section	1 x 0.2-1.5 mm ² / 2 x 0.1-0.75 mm ² 1 x 24-16 AWG / 2 x 27-19 AWG	9,2 x 8 mm M5	Rigid/flexible/ferrule conductor cross section	1 x 25 mm ² / 2 x 16 mm ² 1 x 4 AWG / 2 x 6 AWG 2,5-3 Nm (22-26,6lb-in)	9 x 9 mm M5	1,5-2,5 Nm (13.3 lb-in – 22 lb-in)
	Stripping length	8 mm		Stripping length	11 mm		
75A	Rigid/flexible/cable lug conductor cross section	1 x 0.2-1.5 mm ² / 2 x 0.1-0.75 mm ² 1 x 24-16 AWG / 2 x 27-19 AWG	9,2 x 8 mm M5	Rigid/flexible/ferrule conductor cross section	1 x 25 mm ² / 2 x 16 mm ² 1 x 3 AWG / 2 x 6 AWG 2,5-3 Nm (22-26,6lb-in)	9 x 9 mm M5	1,5-2,5 Nm (13.3 lb-in – 22 lb-in)
	Stripping length	8 mm		Stripping length	11 mm		
90A	Rigid/flexible/cable lug conductor cross section	1 x 0.2-1.5 mm ² / 2 x 0.1-0.75 mm ² 1 x 24-16 AWG / 2 x 27-19 AWG	10,5 mm x 10,7 mm M5	Rigid/flexible/ferrule conductor cross section	35 mm ² 2 AWG 2,5-3 Nm (22-26,6lb-in)	9 x 9 mm M5	1,5-2,5 Nm (13.3 lb-in – 22 lb-in)
	Stripping length	8 mm		Stripping length	13 mm		
120A	Rigid/flexible/cable lug conductor cross section	1 x 0.2-1.5 mm ² / 2 x 0.1-0.75 mm ² 1 x 24-16 AWG / 2 x 27-19 AWG	9,2 x 8 mm M5	Rigid/flexible/ferrule conductor cross section	1 x 50 mm ² / 2 x 25 mm ² 1 x 1/0 AWG / 2 x 3 AWG 2,5-3 Nm (22-26,6lb-in)	9 x 9 mm M5	1,5-2,5 Nm (13.3 lb-in – 22 lb-in)
	Stripping length	8 mm		Stripping length	13 mm		
Note: Use 60/75°C copper (CU), solid or multi-stranded conductors			Note: Use 75°C copper (CU), multi-stranded conductors				

(*) The screw terminals are only suitable for on-site wiring connection when the wire is equipped with a tube terminal with eyelet. It is possible to make ground connection using a copper bar suitably ground connected and fixed to the heatsink of more GRS-H (WxD) = Width x depth

- Nota:**
 For Canadian end-use applications only, an R/C VZCA/7 (or CSA-approved) surge protector is required to be installed in the end-use as shown below:
 - Maximum clamping voltage 800V, for the control input of Type "D" devices.
 - Maximum clamping voltage 2500V, for control input of "A" type devices.
 - Maximum clamping voltage 800V, for the auxiliary output of type "D" and "A" devices.

SCCR FUSES

SCCR CO-ORDINATION FUSES TABLE				
Model	Short circuit current [Arms]	Max fuse size [A]	Bussmann Model Number	Max Voltage [VAC]
GRS-H 15	100.000	40	DFJ-40	600
GRS-H 25	100.000	40	DFJ-40	600
GRS-H 30	100.000	40	DFJ-40	600
GRS-H 40	100.000	40	DFJ-40	600
GRS-H 50	100.000	80	DFJ-80	600
GRS-H 60	100.000	80	DFJ-80	600
GRS-H 75	100.000	80	DFJ-80	600
GRS-H 90	100.000	125	DFJ-125	600
GRS-H 120	100.000	125	DFJ-125	600

The fuses on the above table are representative of all the Bussmann DFJ fuses with lower current ratings
The devices protected with the fuses reported above, still be functional after the short circuit

Short circuit protection:

The product variants listed in the table "SCCR COORDINATION FUSES" are "Suitable For Use On A Circuit Capable Of Delivering Not More Than 100,000 A rms Symmetrical Amperes, 600 Volts Maximum when Protected by fuses.

Attention:

the opening of the branch-circuit protective device may be an indication that a fault has been interrupted. To reduce the risk of fire or electric shocks, current-carrying parts and other components of the device should be examined and replaced if damaged. If burnout of the device occurs, the complete device must be replaced or equivalent.

EXTRARAPID FUSES

Model	Fuse manufacturer	Fuse Model size
GRS-H 15, GRS-H 15/48, GRS-H 15/60	Bussmann Div Cooper (UK) Ltd	FWC16A10F 10x38
GRS-H 25, GRS-H 25/48, GRS-H 25/60	Bussmann Div Cooper (UK) Ltd	FWC25A10F 10x38
GRS-H 30, GRS-H 30/48, GRS-H 30/60	Bussmann Div Cooper (UK) Ltd	FWP40A14F 14x51
GRS-H 40, GRS-H 40/48, GRS-H 40/60	Bussmann Div Cooper (UK) Ltd	FWP40A14F 14x51
GRS-H 50, GRS-H 50/48, GRS-H 50/60	Bussmann Div Cooper (UK) Ltd	FWP63A22F 22x58
GRS-H 60, GRS-H 60/48, GRS-H 60/60, GRS-H 75, GRS-H 75/48, GRS-H 75/60	Bussmann Div Cooper (UK) Ltd	FWP80A22F 22x58
GRS-H 90, GRS-H 90/48, GRS-H 90/60	Bussmann Div Cooper (UK) Ltd	FWP100A22F 22x58
GRS-H 120, GRS-H 120/48, GRS-H 120/60	Bussmann International Inc. USA	170M1418 000-TN/80

FANS (for 90A/120A models only)

Model	Code	Type	Supply
90A FAN60	363484	230 Vac 60mm x 60mm x 30mm for 90A models	Separate power supply
120A FAN60	363011	230Vac 80mm x 80mm x 38 mm for 120A models	Separate power supply
90A FAN61	363485	115Vac 60mm x 60mm x 30 mm for 90A models	Separate power supply
120A FAN61	363003	115Vac 80mm x 80mm x 38 mm for 120A models	Separate power supply
FAN62	363037	24 Vdc 60mm x 60mm x 25mm	Separate power supply
FAN63	363037	24 Vdc 60mm x 60mm x 25mm	Internally powered by GRS-H



PERIODIC CLEANING

Every 6-12 months (depending on dust in the place where it is installed), blow a jet of compressed air downward through the cooling heatsink (on the opposite side of the fan).

In this way both the heat sink and the cooling fan are cleaned.



IN THE EVENT OF OVERTEMPERATURE ALARM

If periodic cleaning does not eliminate the problem, perform the following operations:

1. Disconnect the fan cables from the terminal block (if present) or disconnect the fan connector from the GRS-H (FAN63).
2. Unscrew the screws securing the fan to the support brackets
3. Check the condition of the fan, clean it or replace it
4. Reassemble the fan

FANS (for 90A/120A models only)

Caution: make sure that the arrow showing the direction of the air flow on the fan is pointing toward the heat sink

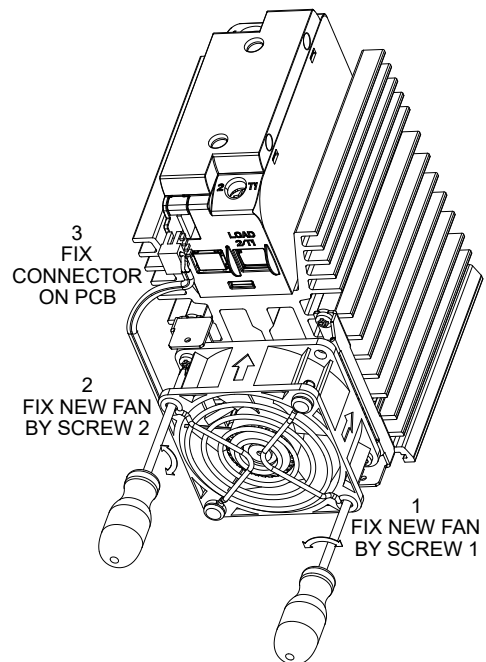
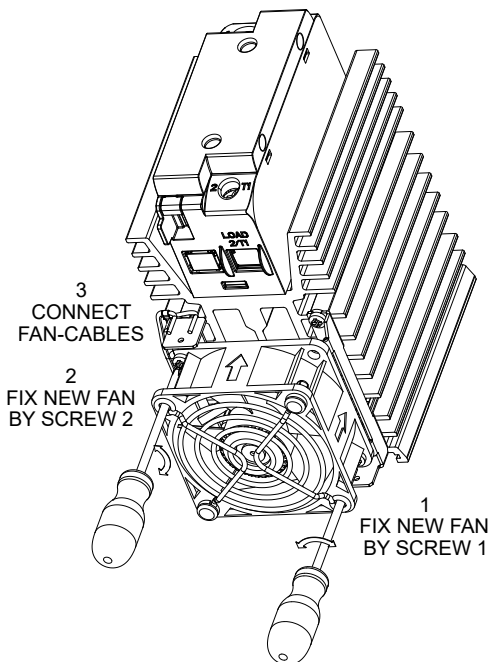
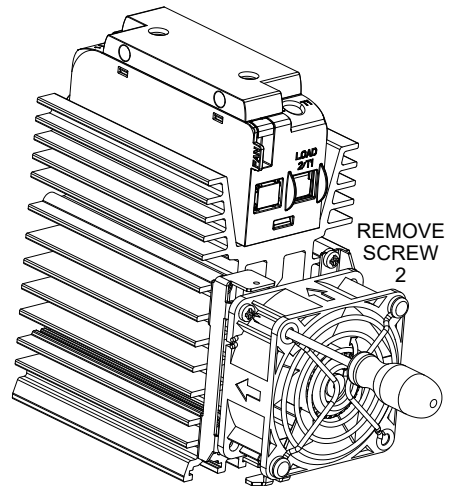
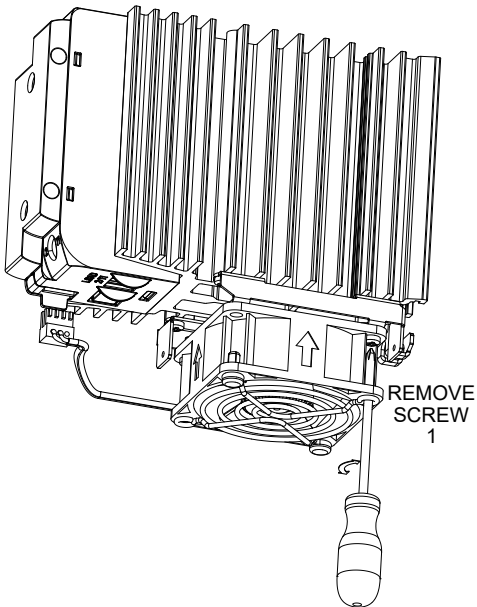
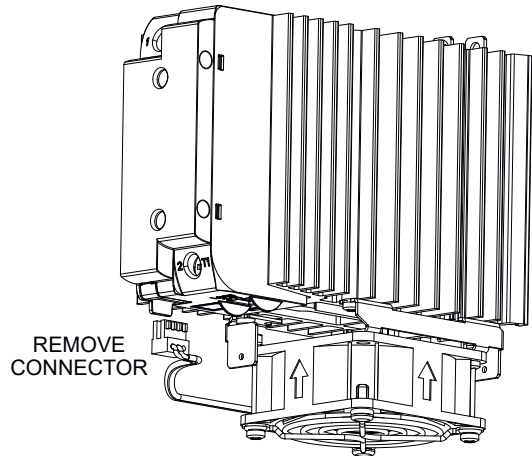
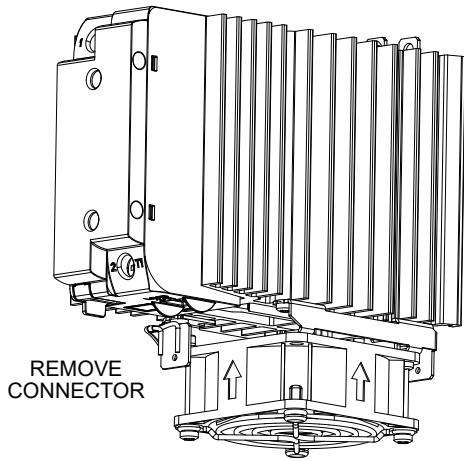

Use a Phillips screwdriver with a max. diameter of 3.5mm.

Rated current curves as a function of ambient temperature (minimum distance between GRS-H of 20mm).

DERATING CURVES GRS-H 15 ÷ 30A

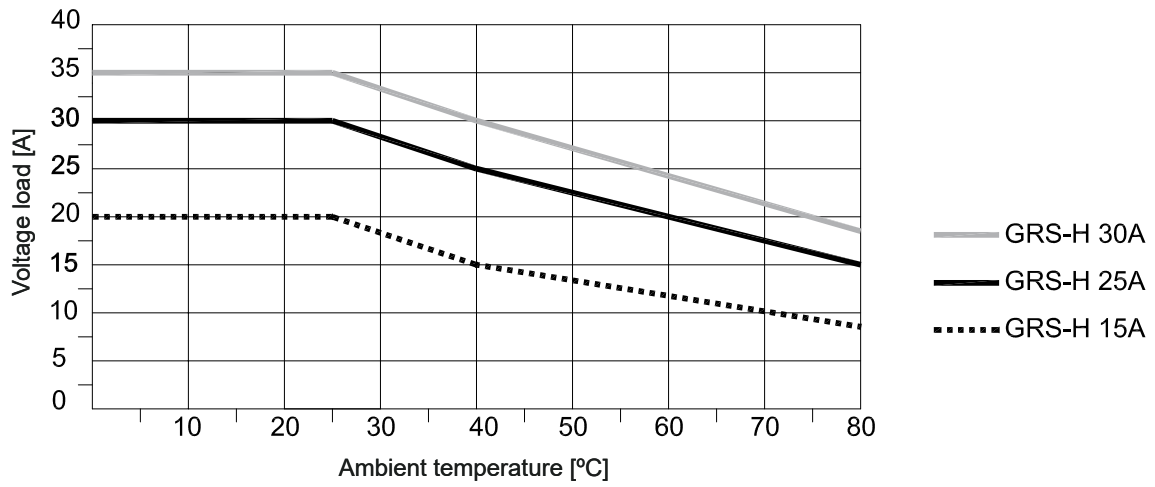

DERATING CURVES GRS-H 40 ÷ 60A

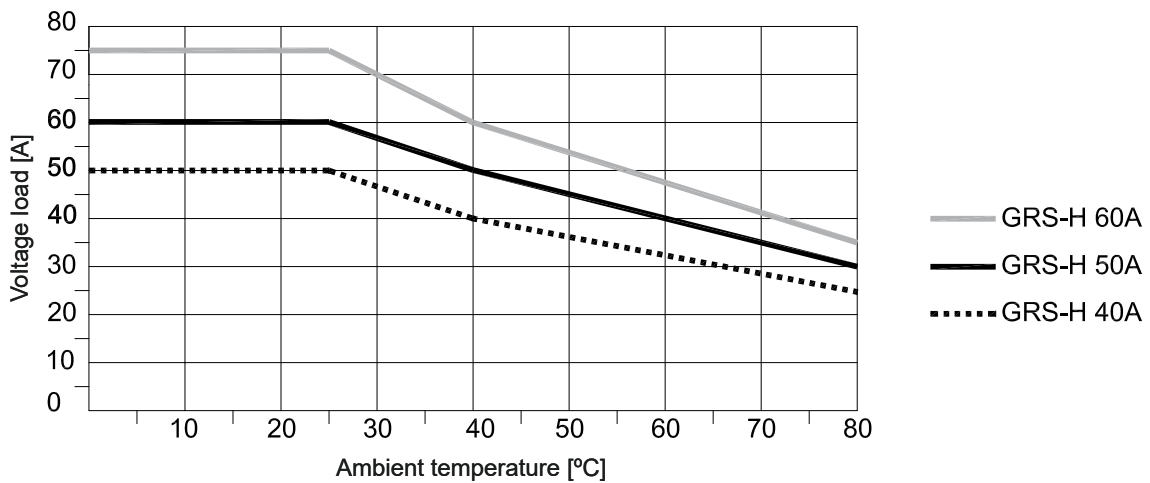

DERATING CURVES GRS-H 75 ÷ 120A

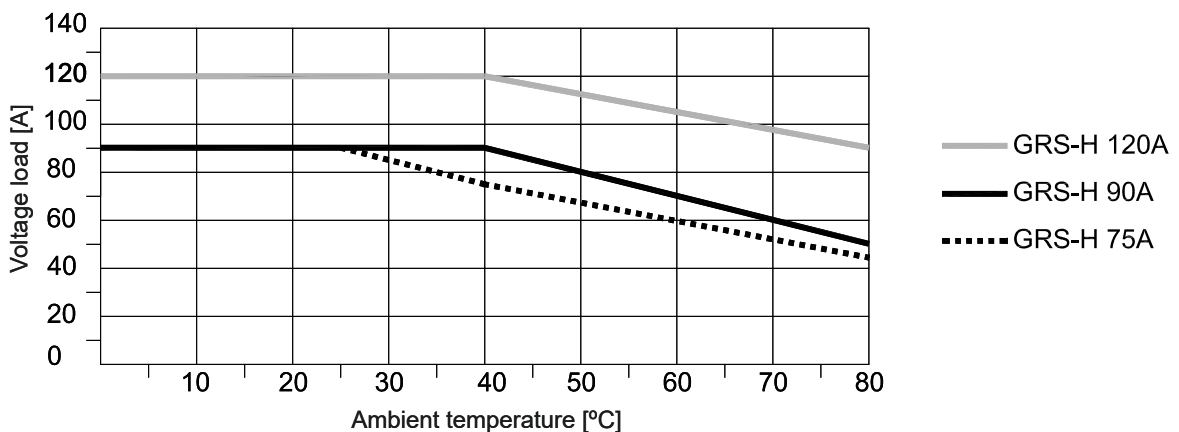

N.B: The curves of the GRS-H 90/120 refer to the device complete with a working specified fan.

Rated current curves as a function of the horizontal distance between the GRS-Hs (ambient temperature 40 °C).

DERATING CURVES GRS-H 15 ÷ 30A

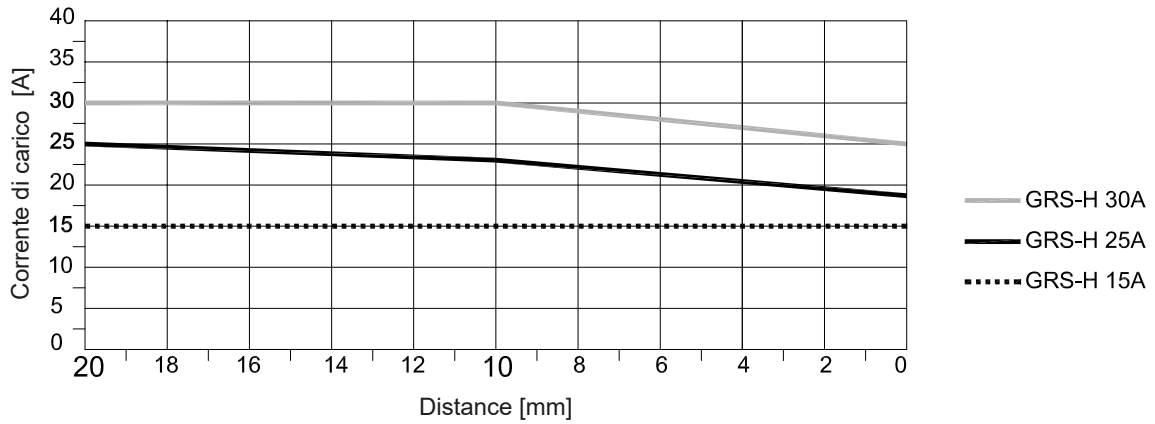

DERATING CURVES GRS-H 40 ÷ 60A

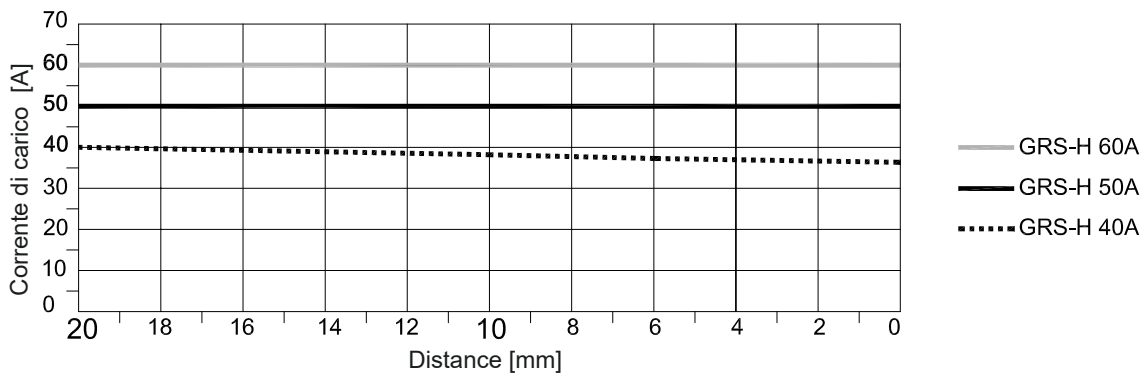

DERATING CURVES GRS-H 75 ÷ 120A

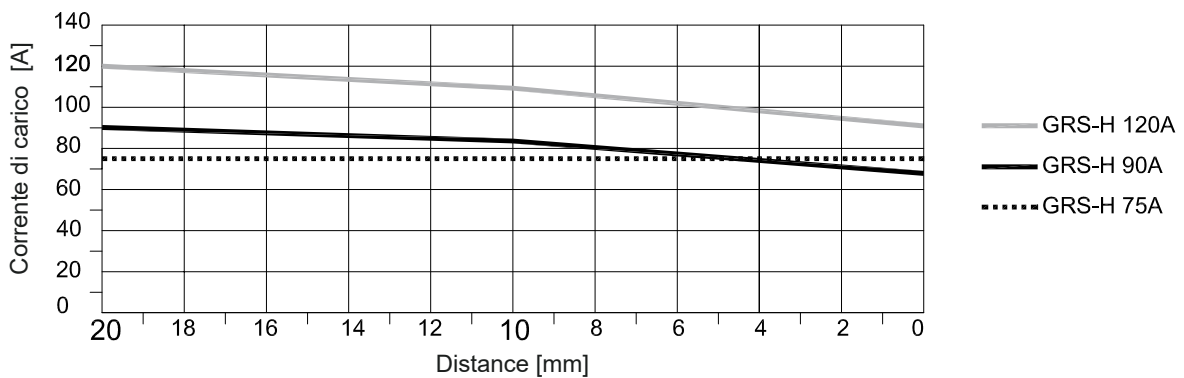

N.B: The curves of the GRS-H 90/120 refer to the device complete with a working standard fan.

GRS-H - [] - [] - [] - [] - [] - 0 - 0

Rated current	
15Aac	15
25Aac	25
30Aac	30
40Aac	40
50Aac	50
60Aac	60
75Aac	75
90Aac	90
120Aac	120

Rated voltage	
480Vac	48
600Vac	60

Input type	
6 ... 32 Vdc	D
20 ... 260 Vac / Vdc	A

Future developments	
0	Nessuna

Control terminal	
0	Push In

FANS (for 90A/120A models only)	
0	None
FAN60	230Vac 60x60x30 mm for 90A models
	230Vac 80x80x38 mm for 120A models
FAN61	115Vac 60x60x30 mm for 90A models
	115Vac 80x80x38 mm for 120A models
FAN62	24Vdc 60x60x25 mm
FAN63	24Vdc 60x60x25 mm (2)

OPTIONS	
0	None
1	Thermal alarm and load interrupted Insulated contact (NO) (1)
2	Thermal alarm and load interrupted Insulated contact (NC) (1)
3	Thermal alarm and load interrupted Digital output PNP (NO) (1)
5	Thermal alarm Insulated contact (NC)

Notes:

(1) Not available for Type A input versions

(2) Module-powered fan, available for Type D input and option versions. This option allows you to turn the fan on only when necessary, increasing its useful life.

WARNINGS



WARNING: THIS SYMBOL INDICATES DANGER.

Read the following warnings before installing, connecting or using the device:

- follow instructions precisely when connecting the device.
- always use cables that are suitable for the voltage and current levels indicated in the technical specifications.
- In applications with risk of damage to persons, machines or materials, you **MUST** install auxiliary alarm devices.
- It is advisable to verify frequently that the alarm device is functional even during the normal operation of the equipment.
- **DO NOT** operate the device in rooms with dangerous (flammable or explosive) atmosphere.
- During continuous operation, the heat sink can reach up to 100°C, and stays at a high temperature even after the device is turned off due to thermal inertia; therefore, **DO NOT** touch it and avoid contact with electrical wires.
- do not work on the power part without first disconnecting electrical power to the panel.
- do not remove the cover when the device is powered!

Installation:

- correctly ground the device using the specific terminal.
- power supply lines must be separated from device input and output lines; always check that the supply voltage matches the voltage indicated on the device label.
- avoid dust, humidity, corrosive gases and heat sources.
- respect the installation distances between one device and another (to allow for dissipation of generated heat).
- to keep air in movement, we advise you to install a fan near the GRS-H group in the electrical panel containing the GRS-H.
- respect the indicated dissipation curves

Maintenance:





at regular intervals, check operation of the cooling fans and clean all air ventilation filters.

- repairs must be done out only by trained and specialized personnel. Cut power to the device before accessing internal parts.
- do not clean the box with solvents derived from hydrocarbons (trichloroethylene, gasoline, etc.). Using such solvents will compromise the device's mechanical reliability. Use a clean cloth moistened with ethyl alcohol or water to clean external parts in plastic.

Service:

GEFRAN has a service department. The warranty excludes defects caused by any use not conforming to these instructions.

GEFRAN spa reserves the right to make aesthetic or functional changes at any time and without notice.

	This device conforms to European Union Directive 2014/30/EU and 2014/35/EU as amended with reference to generic standards: EN 61000-6-2 (immunity in industrial environment) EN 61000-6-4 (emission in industrial environment) - EN 61010-1 (safety regulations).
	cULus listed, Conformity UL508 - File: E243386
	EAC, Conformity TC RU C-IT.A132.B.00422
	100 KA when protected by proper fuse